

TOYOTO

Changes for the Better...

INDUSTRIAL SEWING MACHINE

LZ2-2160BOB-3F
(3 Function in one machine)

Single Needle, Flat bed, Large Horizontal axis hook,
Zigzag Sewing Machine

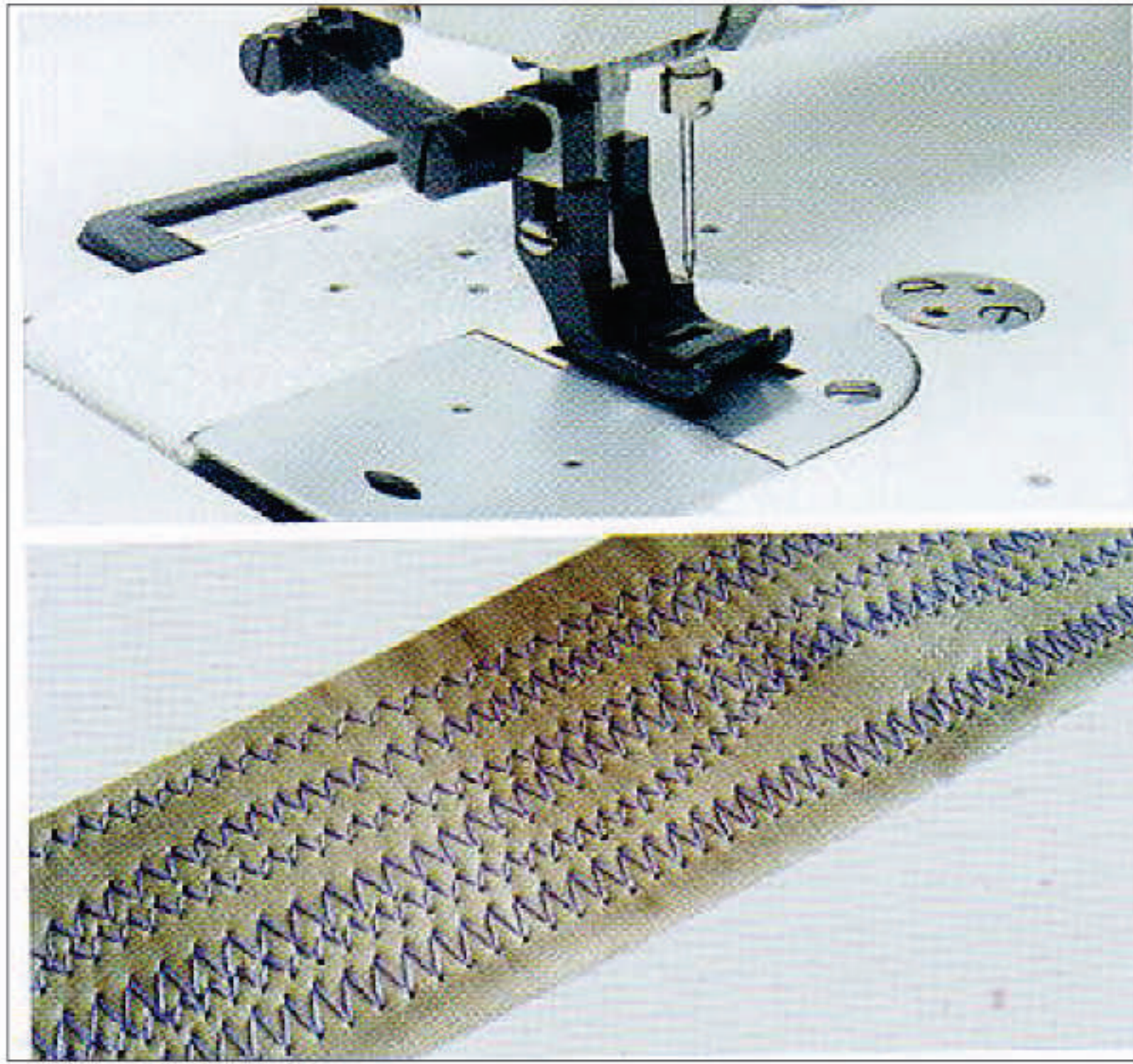

■ Main Features

With change of cam, the machine can be converted from single step zig-zag to two step zig-zag or three step zig-zag.

■ Specification

LZ2-2160BOB-3F	●	●	—	●	1700	5	9/13	10	●	●	●	Dpx17	260x100	●	●	●

TOYOTO

INDUSTRIAL SEWING MACHINE

Changes for the Better...

LZ2-2161-BOB

Heavy Duty, Single Needle, 3-Point (2-Step),
Zig-Zag, Lockstitch Sewing Machine



■ Main Features

1. Equipped with large hook, the bobbin has a twice larger capacity than that of regular hook. This is convenient for long materials sewing as well as with thick thread.
2. The amount of thread on the bobbin is twice, improves sewing efficiency.
3. Open type of top cover simplifies the maintenance.
4. Applied the newly improved device, so increased the function & durability, and simplified the maintenance.
5. Especially desirable where reinforced stitch is necessary.
6. Locking zigzag with regulator.
7. Reverse feed by simple lever operation.
8. Suitable for stitching the elastic & stretch materials, such as: canvas, nylon, vinyl, leather, etc.
9. Especially desirable where reinforced stitching is necessary for boat and truck cover, tents, awnings, sails, parachutes, tarpaulins,etc.
10. Extra pressure foot lift & thick needle.

■ Specification

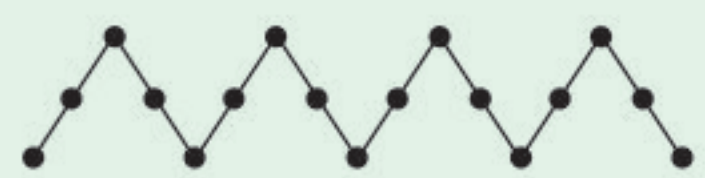
Sewing speed (spm)	Stitch length (mm)	Stitch width (mm)	Presser foot clearance (mm)	Needle	Needle bar stroke (mm)	Hook	Feed mechanism	Stitch diagram
2800	5	10	8 by hand 13 by knee	#18~#24	34	Large hook	Drop feed	 3-Point (2-Step)

TOYOTO

INDUSTRIAL SEWING MACHINE

PB-401G

Single Needle Chain Stitch Glove Sewing Machine







Changes for the Better...



■ Main Features

- Suitable for sewing gloves and other small tubular materials.
- Good sewing stitch.
- This machine does not need the bobbin winding.

■ Specification

						Size	N.W./G.W.
PB-401G	800	80/12#- 90/14#	4	13	160x190	530x250x430	

TOYOTO

Changes for the Better...

INDUSTRIAL SEWING MACHINE

PB-8365



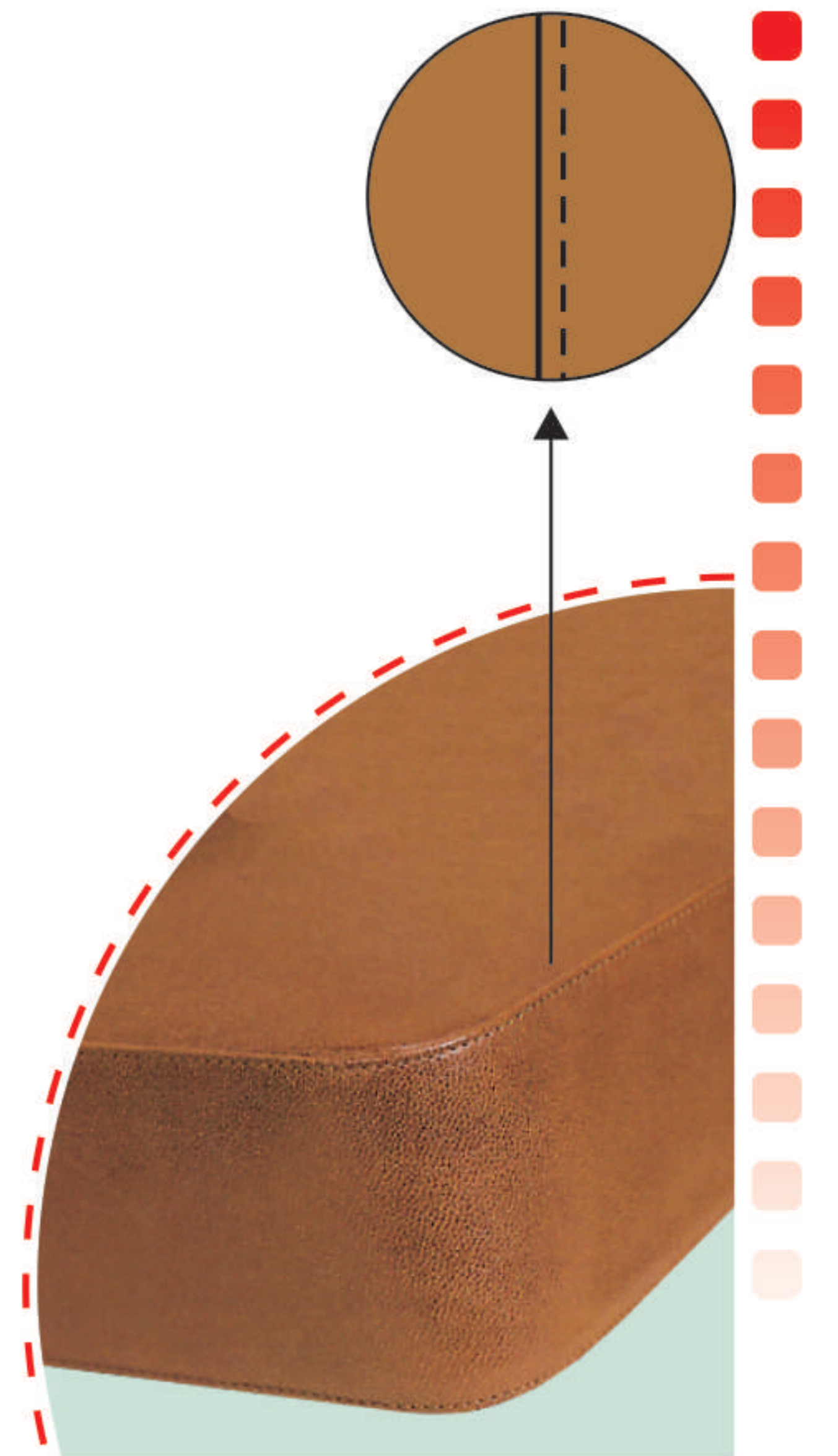





SINGLE NEEDLE HIGH POSTBED LOCKSTITCH
SEWING MACHINE WITH UNISON FEED (LEFT SIDE POST)



■ Main Features

- High-postbed design (postbed height : 443mm & postbed diameter : 47mm)
- Distance from edge to needle is 2.6mm, hence can stitch at extreme corners.
- With special designed needle plate, suitable for stitching the small-curved portions such as the bottoms, gores & corners of the bags.
- The stitch length could be easily adjusted with the stitch dial.
- With unison feed, could obtain a smooth sewing quality on either thin or thick materials.
- Backtacking only with gentle press on the backtacking bar, convenient operation.
- These machines are ideally suited for stitching the large & three-dimensional articles such as boots, bags, suitcase, etc.

■ Specifications

 Model	 Max.Sewing Speed	 Needle System	 Needle Bar Stroke	 Stitch Length	 Presser Foot Lift	 Sewing Material	 Alternating Movement
PB-8365	1600 s.p.m	DP x 17	36 mm	6 mm	15 mm	Medium Heavy	3 ~ 7 mm

TOYOTO

INDUSTRIAL SEWING MACHINE

Changes for the Better...

PB-8369MHR-D2

Single Needle, Needle Feed Top & Bottom Roller Feed Slender Post bed Sewing Machine With Direct Drive, Automatic pressure Foot Lifter and Auto Backstitch



■ Main Features

1. Special designed feeding mechanism, could narrow the distance between the needle and the side of postbed, It is suitable for stitching the three-dimensional or small-curved leather bags, shoes etc.
2. Due to special unison feed, no wrinkle in light material and fine stitch in heavy material.
3. Special designed bobbin case opener, the bobbin case is close to the hook and the distance between the needle and the side of postbed is very tiny.
4. Equipped with, easy-operating safety clutch to protect rotating hook from damage.
5. Suitable for stitching the small-curved portions & three-dimensional articles, such as baby's & children's shoes, boots, suitcase, bottoms & corners of the bags etc.

■ Specifications

Model no.	Sewing speed (spm)	Post-height (mm)	Post-position	Stitch length (mm)	Presser foot clearance (mm)	Needle	Needle bar stroke (mm)	Hook
PB-8369MHR-D2	2500	315	Right	7	15	DP x 5,16#	38	Standard

TOYOTO

Changes for the Better...

INDUSTRIAL SEWING MACHINE

PB-8369MHR-D2

Single Needle, Needle Feed Top & Bottom Roller Feed Slender Post bed Sewing Machine With Direct Drive, Automatic pressure Foot Lifter and Auto Backstitch



■ Main Features

1. Special designed feeding mechanism, could narrow the distance between the needle and the side of postbed, It is suitable for stitching the three-dimensional or small-curved leather bags, shoes etc.
2. Due to special unison feed, no wrinkle in light material and fine stitch in heavy material.
3. Special designed bobbin case opener, the bobbin case is close to the hook and the distance between the needle and the side of postbed is very tiny.
4. Equipped with, easy-operating safety clutch to protect rotating hook from damage.
5. Suitable for stitching the small-curved portions & three-dimensional articles, such as baby's & children's shoes, boots, suitcase, bottoms & corners of the bags etc.

■ Specifications

Model no.	Sewing speed (spm)	Post-height (mm)	Post-position	Stitch length (mm)	Presser foot clearance (mm)	Needle	Needle bar stroke (mm)	Hook
PB-8369MHR-D2	2500	315	Right	7	15	DP x 5,16#	38	Standard

TOYOTO

Changes for the Better...

INDUSTRIAL SEWING MACHINE

PBZ-204H-2

1&2 Needle, Compound Feed, Ornamental Stitch, Thick Thread
Post Bed, Computerized Sewing Machine

PBZ-204H-2A

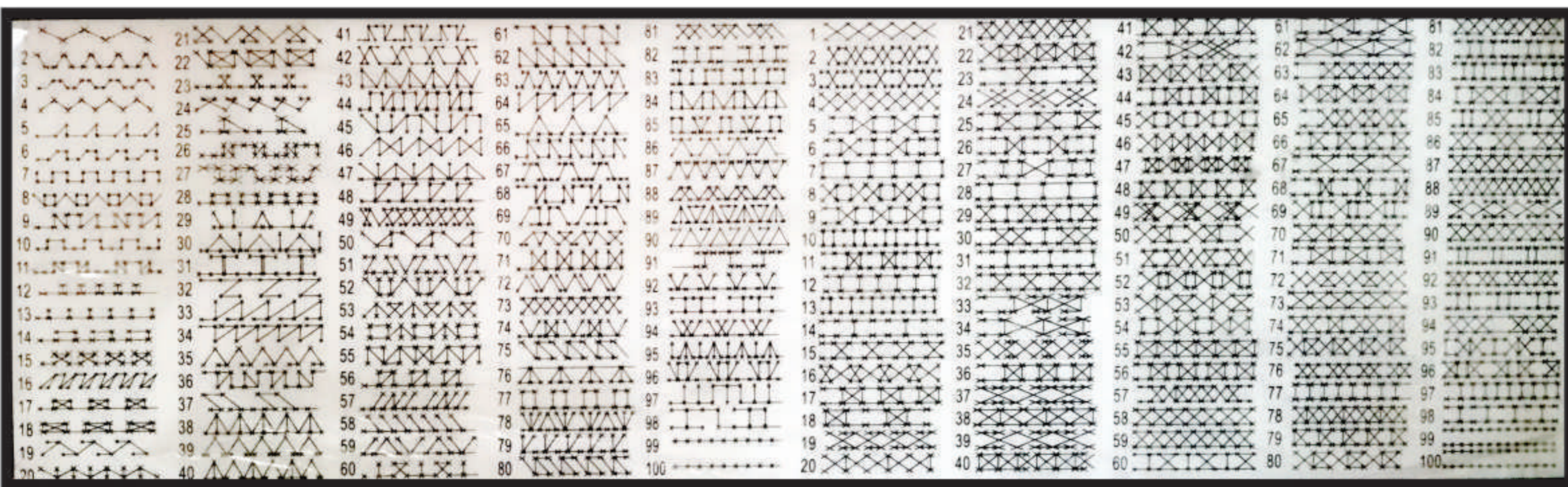
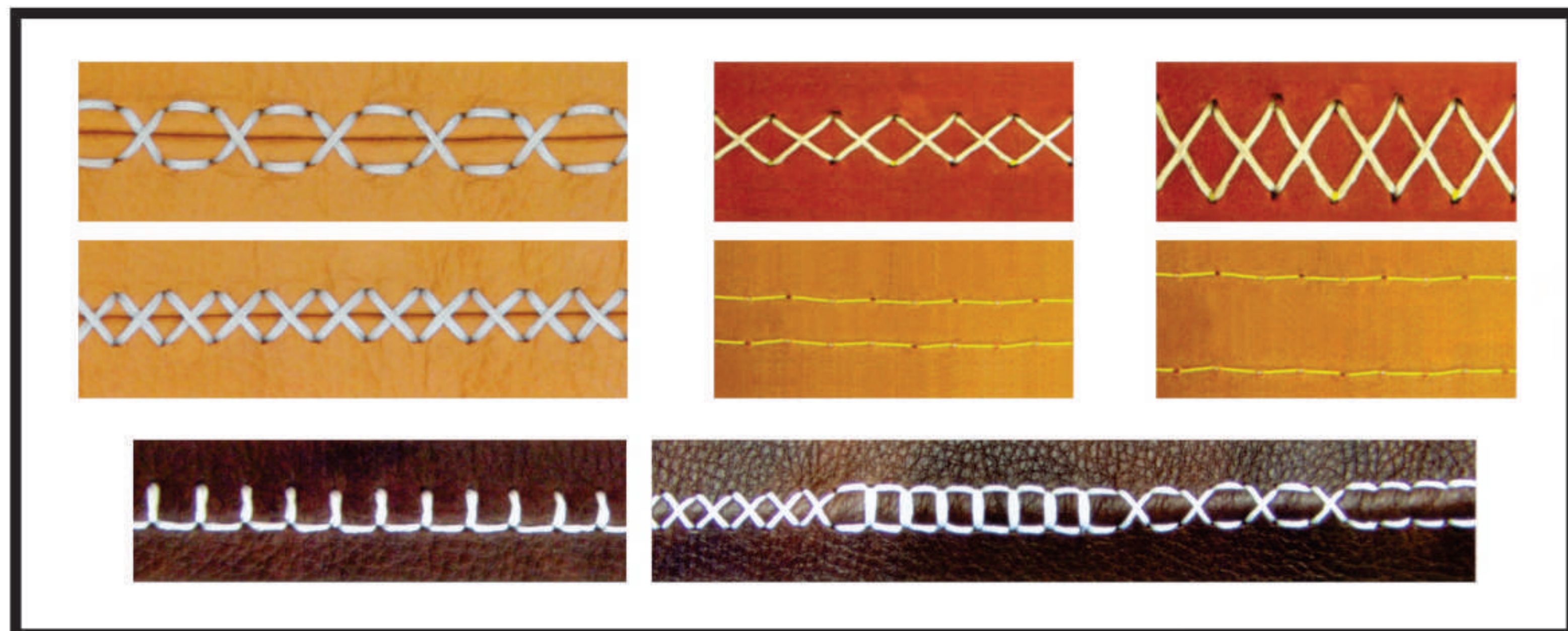

1&2 Needle, Compound Feed, Ornamental Stitch, Thick Thread
Post Bed, Computerized Sewing Machine



❖ Main Features

This series machines are double needle, post bed, compound feed with walking foot, electronic ornamental stitch machine, equipped with double large shuttle hook and touchable panel, which can sew 200 different patterns, even can design new patterns through the pattern edit software. It is suitable for sewing heavy to extra heavy duty materials, such as sofa, car seats, etc.

❖ Specification

												
PBZ-204H-2	●	●	●	400	12	22	7.9-18	DY×3	320x340	●	●	●
PBZ-204H-2A	●	●	●	400	12	22	7.9-18	DY×3	320x340	●	●	●

PBZ-2391

Single Needle, Top & Bottom Feed, 2-Point < 1-Step > Zigzag Postbed Sewing Machine {Large hook}



■ Main Features

Applied with the newly improved device, so increased the function & strength & durability and simplified the maintenance.

Walking foot and feed dog make uniform and beautiful stitches to be obtained.

- Open type of top cover simplified the maintenance.
- Applied with large hook ensures high sewing efficiency.
- Suitable for stitching the small-curved portions & three-dimensional articles, such the cylinder materials, shoes, handbag and leather products.

■ Specification

Model no.	Max. Width of Zigzag (mm)	Sewing speed (spm)	Max.Stitch length (mm)	Needle bar Stroke	Lift of Presser foot (mm)	Needle system
PBZ-2391	9mm	2000	5mm	34mm	08/16mm	DPX17

TOYOTO

INDUSTRIAL SEWING MACHINE

PLK-E430D

Single Needle Direct Drive Lockstitch
Electronic Pattern Sewing Machine

Changes for the Better...



■ Main Features

1. High sewing speed and elegant stitches makes shortest circulation time, perfect sewing quality and high production efficiency.
2. High quality sewing effect as per exact sewing data.
3. Height of presser foot set by operate panel.
4. Motor : 750W Servo Motor.
5. Presser foot device controlled by impulse motor.
6. Standard Thread Trimmer Device : In order to get shortest end of thread, special moving knife and fixed knife are applied.
7. Standard wiper device and thread wipper device.
8. Work Clamp Height : Max. 17 mm
9. Work Clamp Lifter : Pulse-motor driven mechanism
10. Clean Sewing : Rotating hook is lubricate with clean oil but no need for needle bar. it is controlled by direct drive, no belt shavings will make sewing material dirty.
11. Flash Memory Data Storage Method : Due to usage of compact flash card, it is easy to find desired sewing pattern (editor software) through control panel.
12. Less Electricity Consumption : It applies computerized direct drive way without transmission lost and equipped with small-scaled energy saving motor.

■ Specification

Sewing Speed (spm)	Stitch Length (mm)	Max. Pattern Size (mm)	Max. Stitch No.	No. of Pattern Programs	No. of Cycle Programs	Hook	Feed Mechanism	Memory	Lubrication	Weight
3200	0.05-12.7	40 x 30	200,000	150	9	Shuttle	Intermittent	EP-ROM	Automatic	Head Approx. 56 kg

TOYOTO

INDUSTRIAL SEWING MACHINE

Changes for the Better...

PLK-E-430G-JDB

Automatic Backpack Belt Stitching Machine



Specifications

- Rolling, feeding, stitching all at once. Automatic ring-shape belt sewing
- machine is mainly used to sew various ring-shaped bag belts.
- With moving rolling and feeding device, the pattern could be programmed.
- sewing area 15-40mm, rolling length 10-60mm

Model	PLK-E-430G-JDB
Line	Sing-needle flat seam
Highest sewing speed	3200 rpm
(XxY) Sewing area device	40x30mm
Cloth feeding mode	Intermittentfeeding (Pulse motor drive mode)
Needle length	0.05-12.7mm
Max. needles amount	5000V/1 ¹ MMV/ 5000 needles/1 pattern
Presser foot lift mode	Pneumatic
Raising amount by intermittent presser foot	Max. 17mm
Recyle programme Amount	30 cycles(50 programs for each)
Motor	AC/ AC servomotor 550W
Power	Single phasel 00-120V, 200-240V 3-phase 200-240V, 380-415V, 350V
Air pressure	0.5Mpa , 1.8L/min

TOYOTO

INDUSTRIAL SEWING MACHINE

Changes for the Better...

PLK-E1301X-B
PLK-E1302XY-B

Computerised Buckle Sewing Machine for leather belts

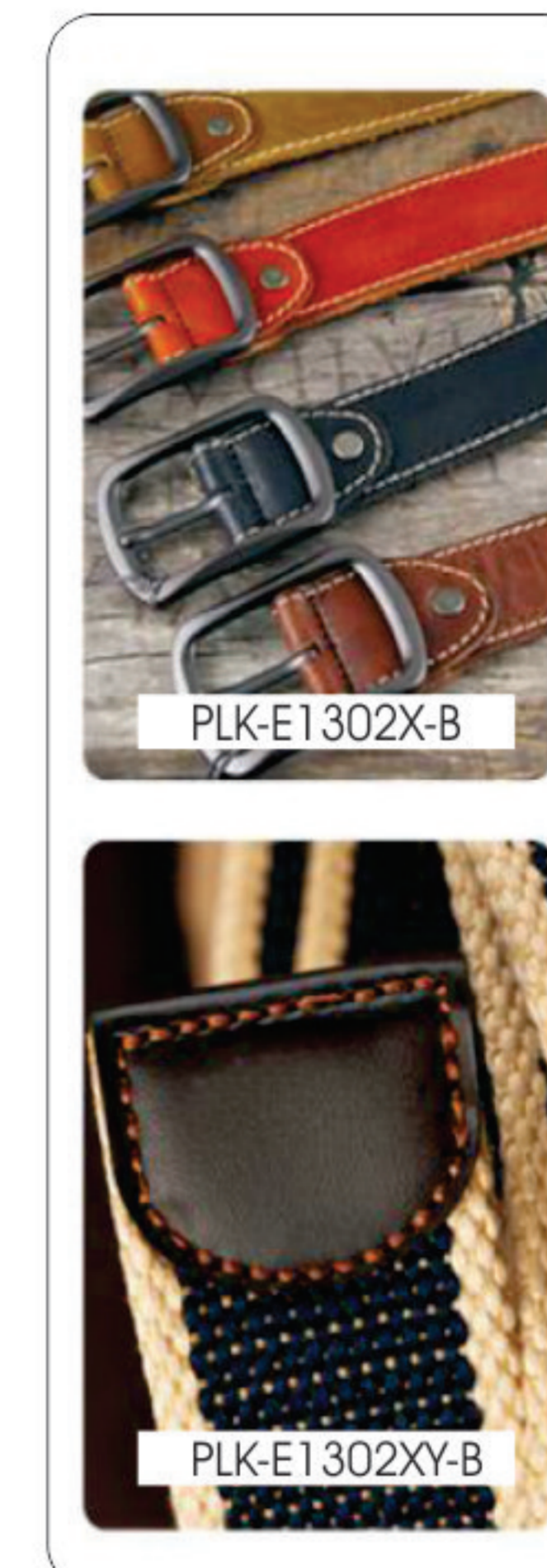

■ Main Features

1. Specialized for buckle component stitching, such as bag, belt, webbing, backstrap.
2. With back feeding stitching and lock stitch function to ensure the thread in neat and beautiful.
3. Easy operation system provides easy operation for the user, pattern design can be adjustable by the machine or computer.

■ Specification

Model no.	PLK-E1301X-B	PLK-E1302XY-B
Sewing area	0.5-80mm	60x80mm
Max. sewing speed	2350r.p.m	
Applicable needle	Dpx17	
Stitch length	0.05-12mm	
Work holder method	Automatic	
holder method	15mm	
Power supply	220V 50/60HZ	
Prodcy size	720x540x1030mm	720x540x1030mm

TOYOTO

Changes for the Better...

INDUSTRIAL SEWING MACHINE

PLK-E1232-HAD

PLK-E1360-HAD

PLK-E13102-HAD



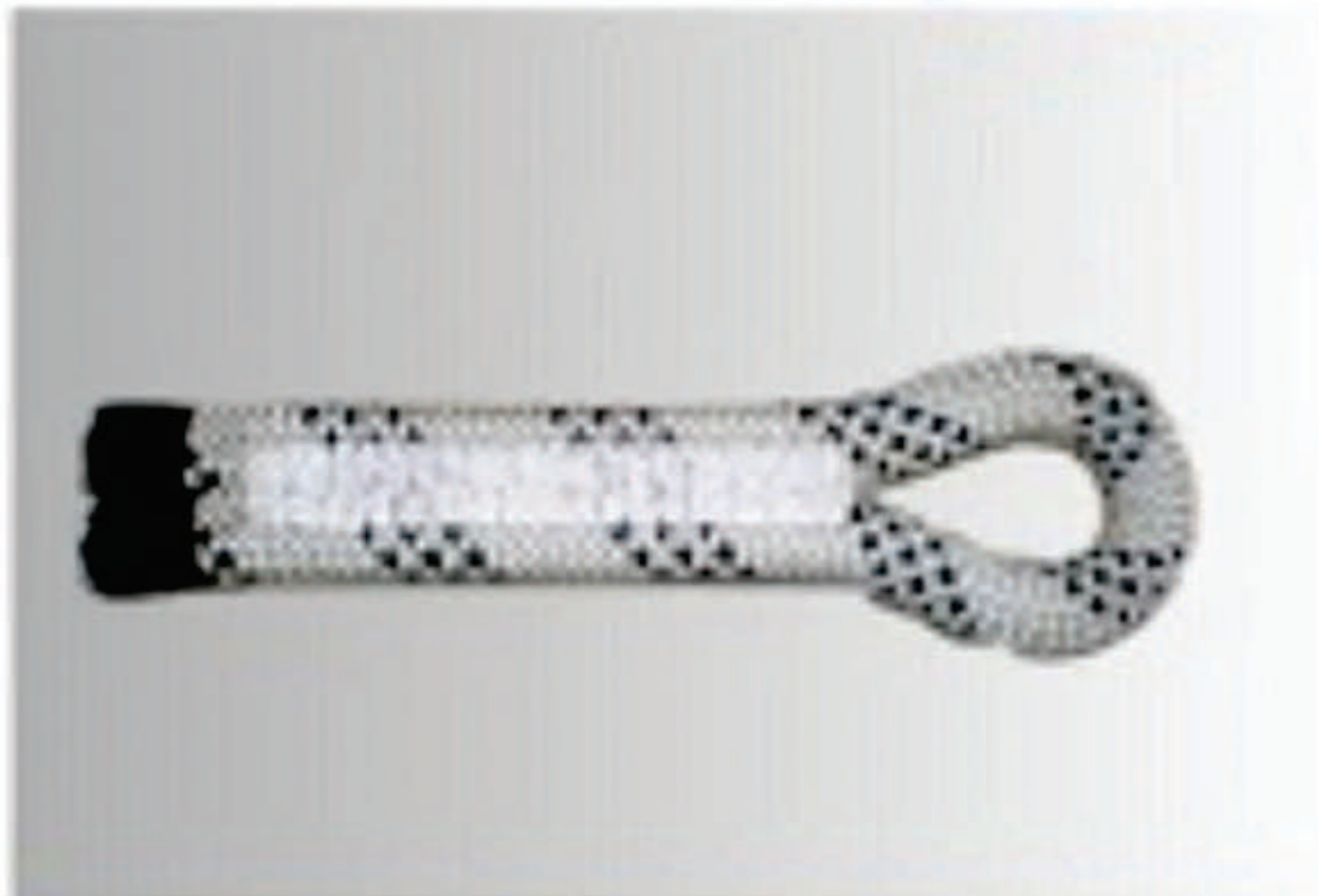





Large Shuttle hook, Thick Thread, CNC Pattern Sewing Machine

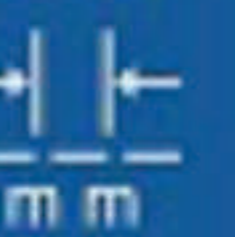

Specifications

This new generation computer-controlled pattern sewing machines with more powerful and reliable control, equipped with large barrel shuttle hook for extra heavy duty material with thick thread. Simple and easy to edit, download and store patterns by touchable panel. The thread burning device as the option. Suitable for sewing safety belts, lifting belts, cargo slings etc.

PLK-E-1232 is especially designed for the ropes(safety ropes, climbing ropes etc).

											
			S.P.M.	mm	mm		mm				
PLK-E1232-HAD	●	●	500	10	22	Dy x 3	120 x 32	●	●	●	
PLK-E1360-HAD	●	●	800	10	22	Dy x 3	130 x 60	●	●	●	
PLK-E1310-HAD	●	●	800	10	22	Dy x 3	130 x 110	●	●	●	

TOYOTO

INDUSTRIAL SEWING MACHINE

Changes for the Better...

PLK-E3020D

Electronically Controlled Pattern
Sewing Machine (area 300x200mm)

PLK-E3525D

Electronically Controlled Pattern
Sewing Machine (area 350x250mm)



■ Main Features

1. High speed sewing machine.
2. Low power consumption, economical and practical.
3. Sewing completely according to stitching data.
4. Raising amount of the presser foot can be adjusted easily by the operation board.
5. Simple program editor with colored LCD screen.
6. High quality sewing with fair lines.
7. High speed sewing with fair lines achieves, excellent sewing quality, high efficiency as well as energy saving.
8. The perforation of the needle can be strengthened.
9. Mass memory can store vast amount of data.
10. Changing memory switches from 3 mode i.e. 2-step lowering, 1-step lowering & Analog lowering.
11. The presser foot can be changed quickly & exactly.
12. The presser foot system can always provide sewing by consistent tension.
13. Fair sewing lines can be achieved by minimum resolution of 0.05mm.
14. It uses the small motor without transmission loss.

■ Specification

Model no.	Sewing area (mm)	Sewing speed (spm)	Stitch length (mm)	Work clamp height (mm)	Presser foot clearance (mm)	Presser foot drive	Max. Needle numbers	Feed mechanism	Memory	Power
PLK-E3020D	300x200	2700	0.05-12.7	30	22	Pulse motor drive	20,000 (stitches/pattern)	Intermittent	Flash (CF) or 3.5" floppy	1-Phase 3-Phase
PLK-E3525D	350x250	2700	0.05-12.7	30	22	Pulse motor drive	20,000 (stitches/pattern)	Intermittent	Flash (CF) or 3.5" floppy	1-Phase 3-Phase

TOYOTO

INDUSTRIAL SEWING MACHINE

Changes for the Better...

PLK-E-XZ1201-B Computerised Pattern Sewing Machine With Rotary Head For Leather Belts



■ Main Features

1. With the rotary machine head, sewing machine head is free rotation.
2. Thanks to the free rotation sewing machine head, the stitches are neat and beautiful just the same as the hand made sewing feature stitching moving direction is the same way but not front and back moving.
3. 15 inch operation panel, its clear chinese-english man-machine interface intelligent fault protection, alarm, fault information display
4. Presser foot high can be adjustable base on material thickness meet different stitching needs for customer.
5. USB ports for ease of storage the dates, support large storage.
6. High powered of 1KW AC servo motor, high performance and stable operation.

■ Specification

Working area	1200x100mm	Fuel filling	Automatic
Max. sewing speed	2500r.p.m	Motor	Servo motor
Stitch	0.05-13.0mm	Rotating shuttle style	Thrice as large capacity full rotary hook
Stitch length	43.2mm	Emergency stop	✓
Work holder method	Automatic	Automatic shear line	✓
holder method	25mm	Packing size	2500x1700x1520mm
Applicable needle	Dpx17		

TOYOTO

INDUSTRIAL SEWING MACHINE

TEB-520 High-Tech Tape Edge Machine

Changes for the Better...



Original Singer head



CTEC sewing head made in TAIWAN



Power panel



Sample of finished product



Main Features

1. The angle of sewing head can be automatically adjusted and the mattress can automatically slow down at every corner.
2. The size of the working table (1800mm*2000mm) can fit all kinds of mattress.
3. Stainless table can push the mattress more smoothly.
4. Original chain stitch sewing head is of higher quality and makes the sewing more efficient.
5. Baking varnish: not easy to fade, dyed into the mattress.
6. Can sew small right angle(R20) corner.

Specification

Table lifting range	Table size(mm)	Weight	Layout	Thickness of mattress	Productivity	Power
140mm	1600x2000 1800x2000	810Kg	3.05x2.8m	30-450mm	10-20units/h	1.2HP 1-Phase,220v,50Hz 3-Phase,380v,50Hz

TOYOTO

INDUSTRIAL SEWING MACHINE

Changes for the Better...

LR2-CORD-P

Leather Cord Stitching Machine with Puller



TOYOTO

INDUSTRIAL SEWING MACHINE

Changes for the Better...

LS2-8BLD-3

SINGLE NEEDLE FLAT-BED HORIZONTAL AXIS HOOK, COMPOUND FEED, LOCKSTITCH SEWING MACHINE

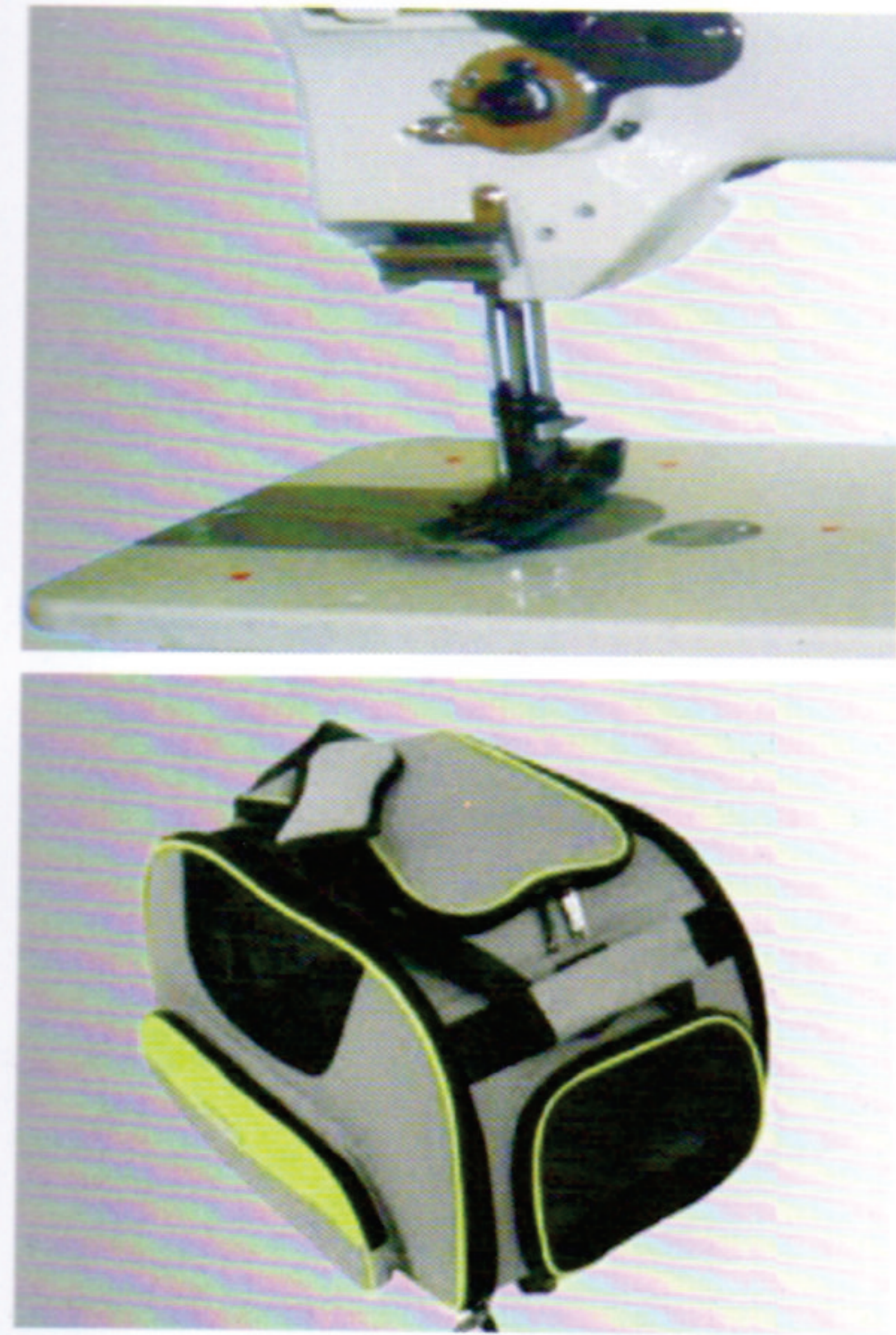

Specifications

- For sewing medium to heavy weight material such as fabrics, leather, vinyl, synthetics and laminated and coated products.
- Suitable for sewing such products as automobile upholstery, covers, sails, tents, camping trailer covers, awnings, bags, luggage, handbags, etc.

Model	Hook	Needle	Foot	S.P.M.	Stitch Length (mm)	Stitch Width (mm)	Presser Foot Height (mm)	Needle Size	Table Width (mm)	M	H	Other
LS2-8BLD-3	●	●	●	2000	10	8.5/13	33.2	DP×17	258×110	●	●	●

TOYOTO

Changes for the Better...

INDUSTRIAL SEWING MACHINE

LS2-3811G SHOE UPPER GATHERING MACHINE



Features

PATENT: By operating the knuckle switch, the two amounts of fullness set on the scales can be alternated as will.

The mechanical fullness control by operating the knuckle at the needle-bar end of the machine, the two amounts of fullness set on the scales can be alternated at will.

- High-speed seamer with differential feed and variable top feed, and with automatic presser foot lifter & edge & tape guide & tape reel bracket.
- The fields of application of this machine version comprises California shoes, clogs, and moccasins. To increase the gathering effect, a tape, which is optionally fed to the needle, is sewn on simultaneously and holds the fullness in place.

Specification

Model	S.P.M	Needle System	Max. Gathering Stitch Length	Basic Stitch Length
LS2-3811G	2000	Dpx17	8mm	2mm

INDUSTRIAL SEWING MACHINE

LU2-8BL-30

Single Needle, Extra Heavy Duty, Long Arm, Flatbed, Compound Feed Lockstitch Sewing Machine

LU2-28BL-30

Double Needle, Extra Heavy Duty, Long Arm, Flatbed, Compound Feed Lockstitch Sewing Machine

LU2-28BLP-30

Double Needle, Extra Heavy Duty, Long Arm, Flatbed, Compound Feed Lockstitch Sewing Machine with Puller & Pneumatic pressure Foot Lift

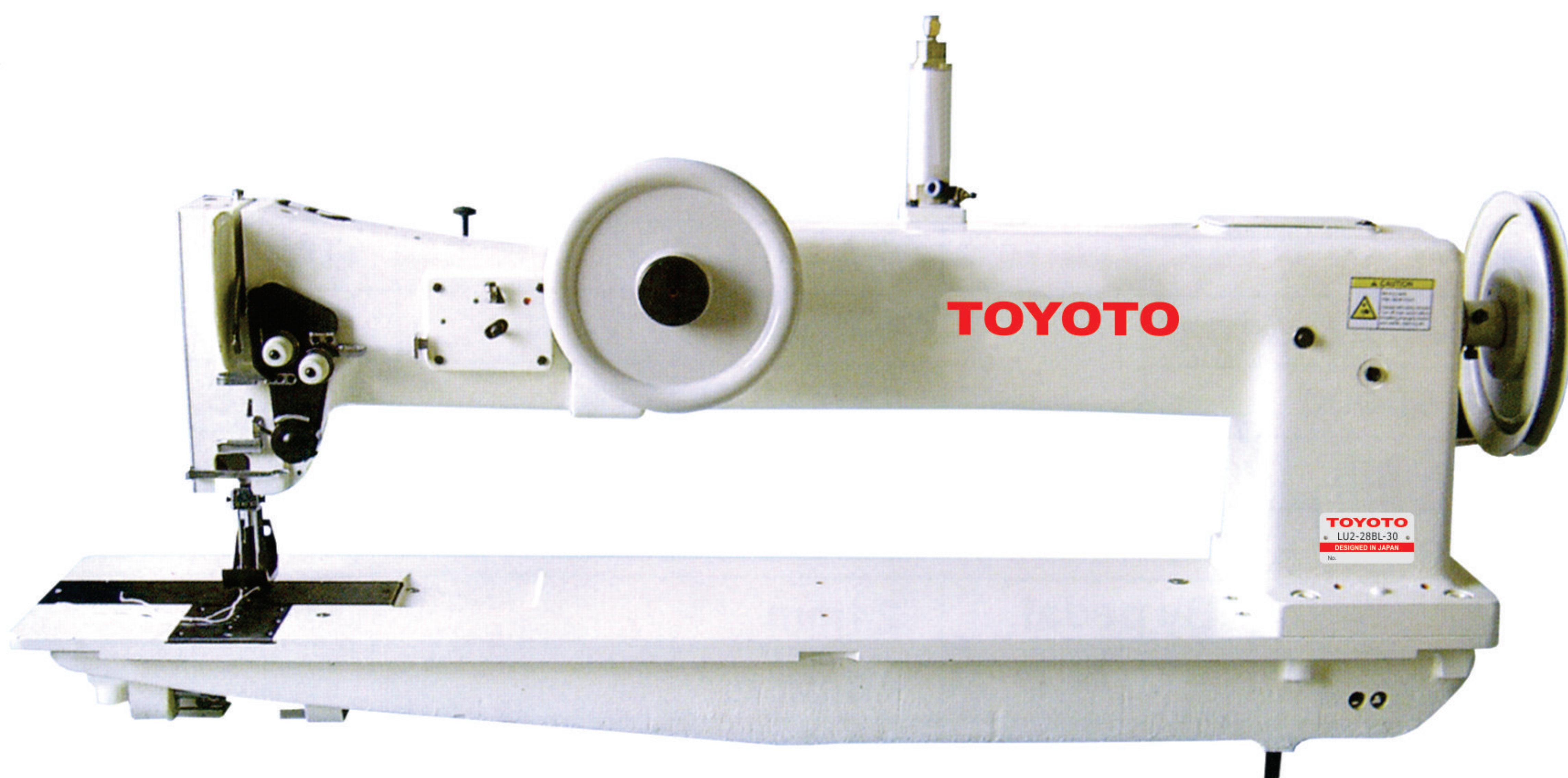
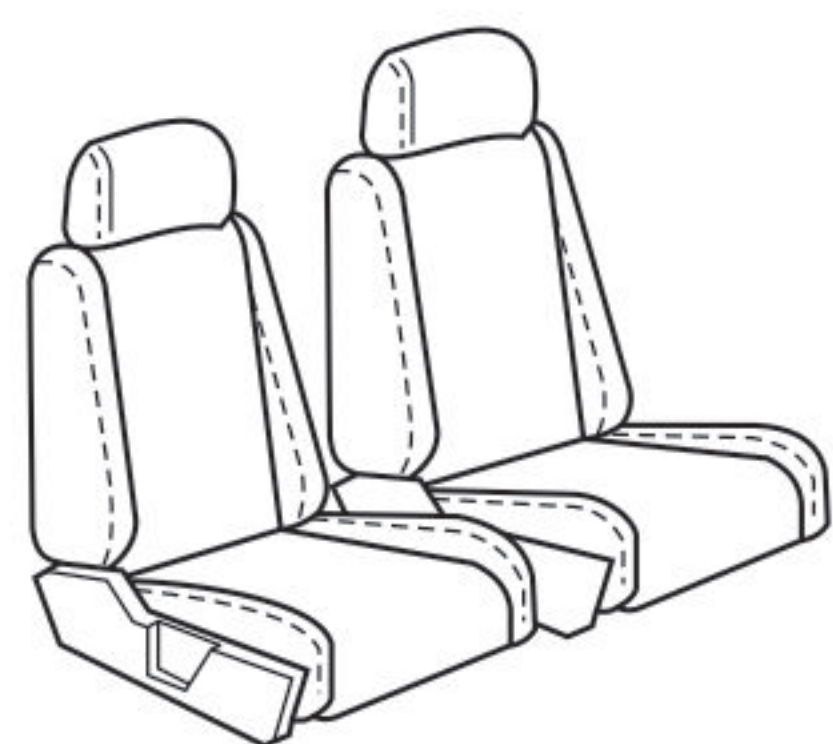
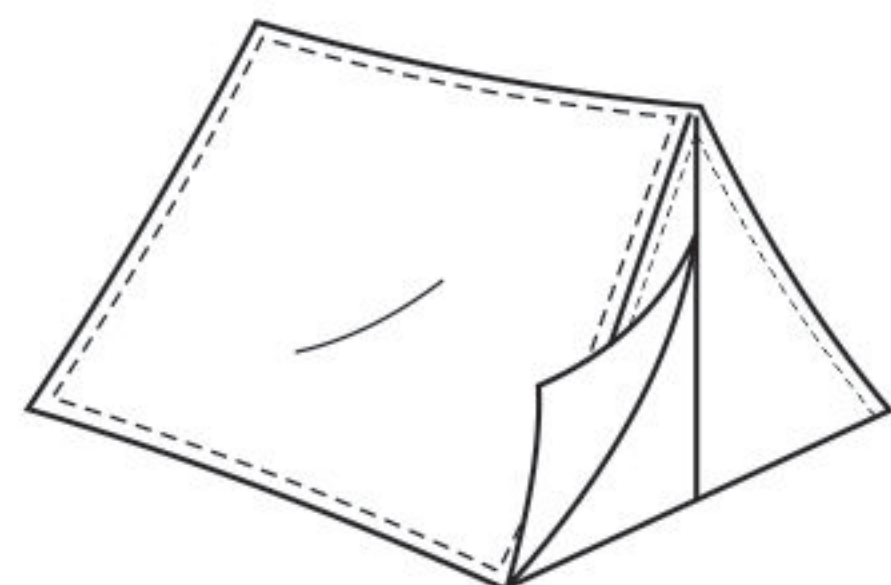

■ Main Features

1. 30" long arm, long and wide working space is suitable for sizable materials such as tents and sails.
2. Extra large vertical axis hook.
3. Compound feed and walking foot mechanism assures even feeding of materials.
4. Safety clutch prevents the hook from being damaged.
5. Reverse feed operated by foot pedal.
6. Front handwheel allows for easy positioning of the needle.
7. Built-in bobbin winder.
8. Both single & two needle version available.
9. These machines are ideally suited for sewing such as tents, traps, truck covers, auto marine and furniture upholstery, field covers, heavy bulky products, canvas, vinyl, leather, synthetics and various coated, laminated & rubberized fabric, etc.

■ Specification

Model no.	Sewing speed (spm)	Stitch length (mm)	Presser foot clearance (mm)	Number of needles	Needle	Needle gauge	Needle bar stroke (mm)	Hook
LU2-8BL-30	1500	10	20 by hand 24 by knee	1	DY x 3	---	47	Extra Large Vertical Hook
LU2-28BL-30	1200	10	20 by hand 24 by knee	2	DY x 3	12.7	47	
LU2-28BLP-30	1200	10	20 by hand 24 by knee	2	DY x 3	12.7	47	

TOYOTO

INDUSTRIAL SEWING MACHINE

Changes for the Better...

LU2-243L-37 Single Needle Flatbed Compound Feed Long Arm Lockstitch Sewing Machine

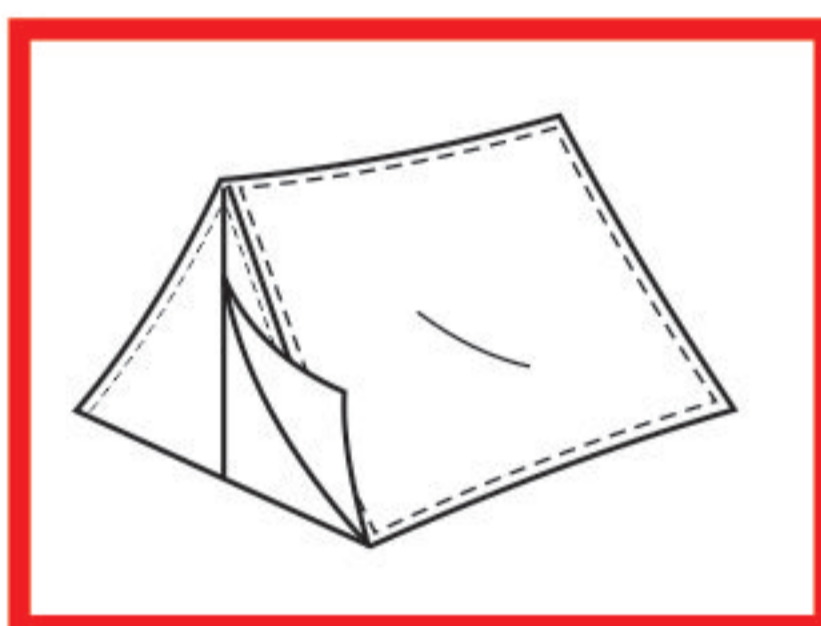
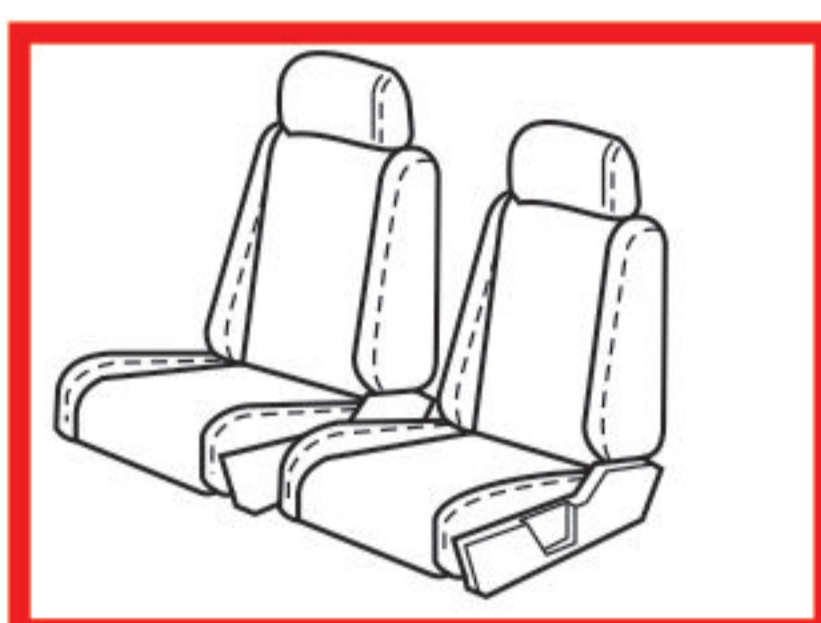

❖ Main Features

1. Super 37" long arm, long and wide working space is suitable for extra large work area.
2. The large shuttle hook and large bobbin designed for sewing extra heavy materials, thus reduce the frequency of bobbin replacement.
3. Safety clutch prevents the hook from being damaged.
4. The built-in bobbin winder provides the convenient operation.
5. Excellent seam appearance.
6. Outstanding capability multi-layers of heavy material due to compound feed system.
7. The high pressure foot is sufficient to sew the extra heavy materials.
8. Suitable for sewing all the extra heavy duty weight materials, especially for the large industrial bags, sails, safety belts, tents, seats etc.

❖ Specifications

Sewing speed (spm)	Stitch length (mm)	Needle bar stroke (mm)	Presser foot clearance (mm)	Working space (mm)	Needle	Hook
800	15	56	13 by hand 22 by knee	635 x 180	DY x 3	Large shuttle hook

TOYOTO

Changes for the Better...

INDUSTRIAL SEWING MACHINE















LU2-1508-AE
LU2-1508-AEL

Single Needle, Flat bed, Large vertical hook, Compound feed, Edge trimming and binding lockstitch sewing machine



- The maximum tape width of LU2-1508-AEL can be up to 9mm & LU2-1508-AE is only 6.5mm.

■ Specification

														
LU2-1508-AE	●	●	●	2000	9	9/16	2.5-6.5	36	135×17(#160) #125-#180	255×100	●	●	—	●
LU2-1508-AEL	●	●	●	1600	9	9/16	2.5-6.5	36	135×17(#160) #125-#180	320×120	—	●	●	●

TOYOTO

INDUSTRIAL SEWING MACHINE







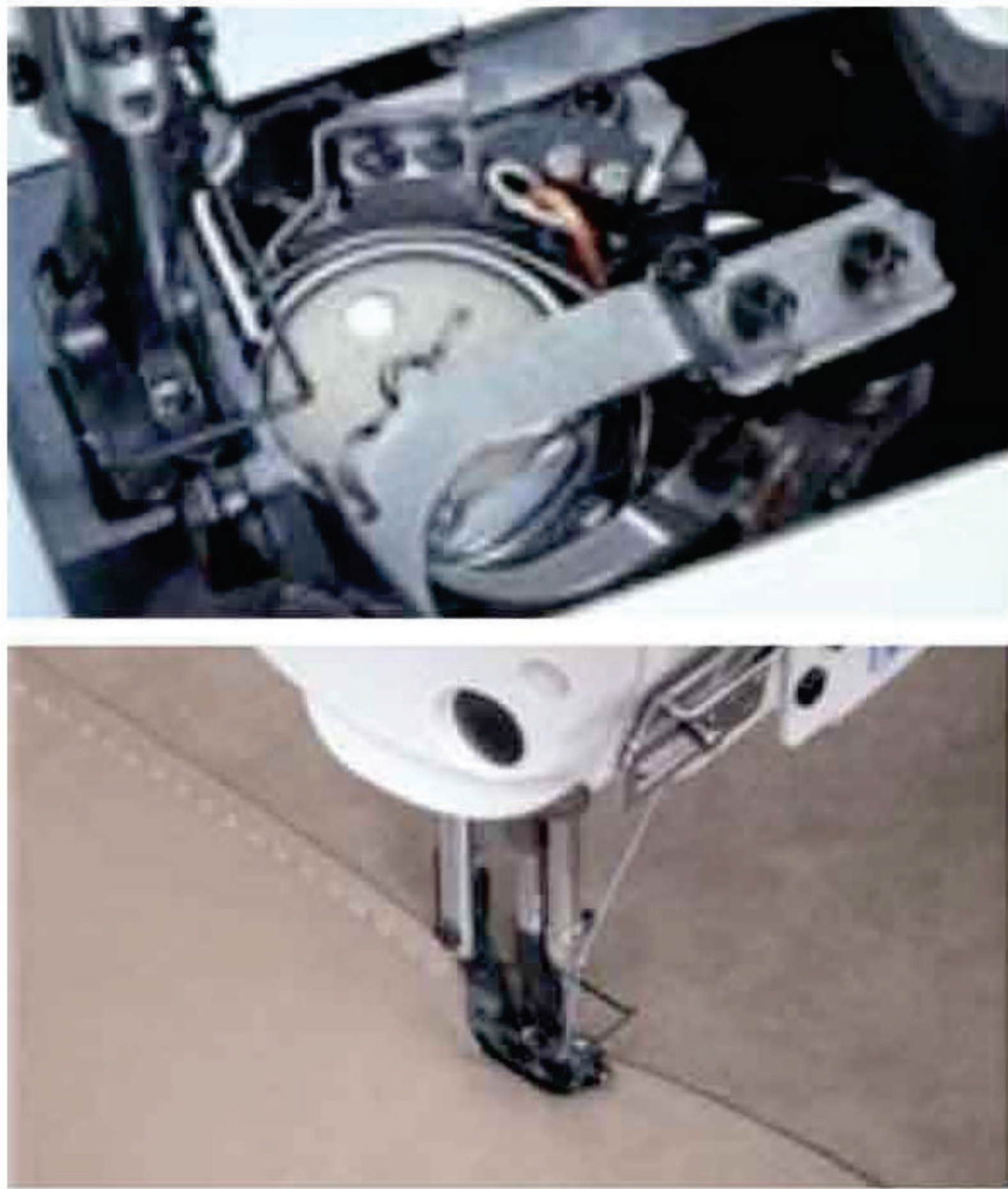









Changes for the Better...

LU2-1510-7
LU2-1560-7

SINGLE/DOUBLE NEEDLE FLAT-BED, LARGE VERTICAL HOOK, COMPOUND FEED, LOCKSTITCH SEWING MACHINE WITH AUTO THREAD TRIMMER



■ Specifications

																
		301			S.P.M.	mm	mm	mm	mm	mm		mm				
LU2-1510-7	●	●	—	●	3000	9	9/16	1-6.5	36	—	135×17(#160) #125-#180	●	255×100	●	●	●
LU2-1560-7	●	—	●	●	3000	9	9/16	1-6.5	36	4.8, 6.4, 7.9, 9.5, 12.7	135×17(#160) #125-#180	●	255×100	●	●	●

TOYOTO

INDUSTRIAL SEWING MACHINE

Changes for the Better...

LU3-205-420C Single Needle Cylinderbed Heavyduty
Unison Feed Lockstitch Sewing Machine

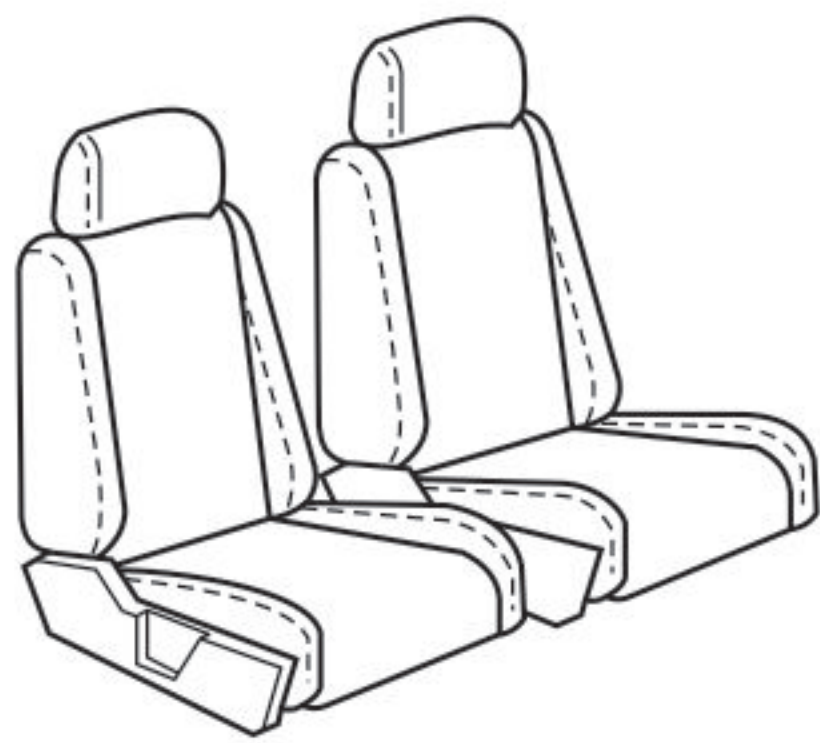
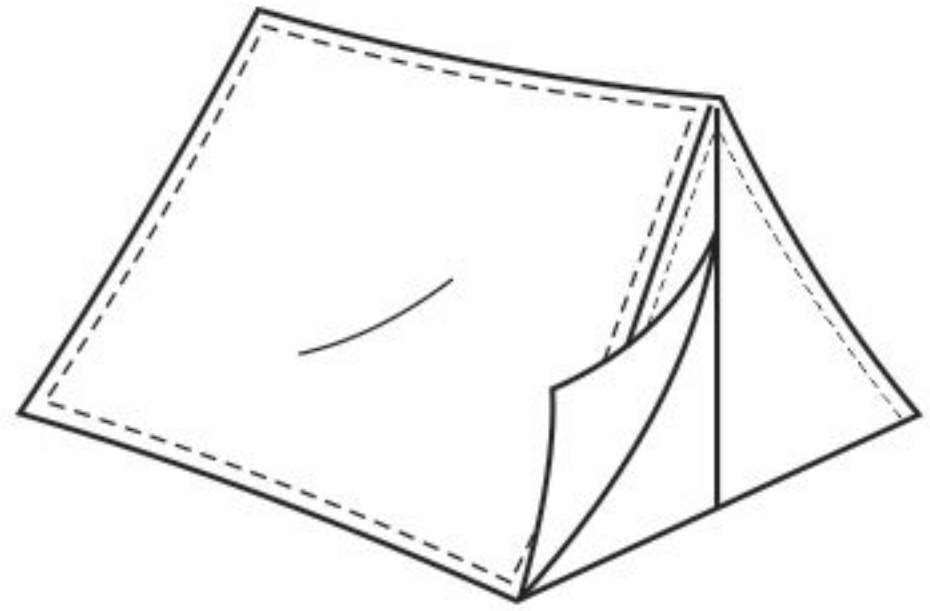

■ Main Features

1. This model is one of the products of extra heavy duty, featuring compound feed mechanism and long arm cylinder bed.
2. Its powerful and steady feeding enables you to sew multiply heavy weight material with nice and beautiful stitches easily.
3. The imported special large shuttle hook and large bobbin capacity offers high efficiency in sewing production.
4. The bobbin winder is on top of the machine head and the presser foot lift can be up to 20mm.
5. Its application covers the stitching of handles of hand bags, baseball, gloves, boots, sports, apparatus, safety bags, tents, seat cushions, case & bag, and other heavy duty or extra heavy duty work.

■ Specifications

Sewing speed (spm)	Stitch length (mm)	Needle bar stroke (mm)	Thread takeup lever stroke (mm)	Presser foot lift (mm)	Needle	Bed-Length (mm)	Bed size dia. (mm)	Hook
800	0-12	56	96	15 by hand 20 by knee	160-230	420	81	Large shuttle hook

TOYOTO

Changes for the Better...

INDUSTRIAL SEWING MACHINE

LU3-441

Single Needle, Unison Feed, Cylinder bed, Lockstitch Machine.
(For extra heavy-weight)



❖ Main Features

1. Powerful unison feed, the machine can sew accurately and easily several sheets of heavy-weight materials piled up together.
The sewing area is up to 420mm, suitable for stitching the huge articles.
The lift of presser foot is up to 20mm, suitable for stitching the extra heavy-weight materials.
Applied the semi-rotary large shuttle & bobbin, could reduce the frequency of changing the bobbin thread, and increase the sewing efficiency.
Suitable for stitching all the extra heavy-weight materials such as the handle of bags, gloves, safety belts, tents, seating, shoes, bags etc.

❖ Specifications

Model no.	Sewing speed (spm)	Stitch length (mm)	Lift of Presser foot (mm)	Dia. of cylinder bed(mm)	Needle	Needle bar stroke (mm)
LU3-441	800	11	20mm	81	DY x 3	56

TOYOTO

INDUSTRIAL SEWING MACHINE

Changes for the Better...

LY2-733H Single Needle, Extra Heavy Duty,
Top & Bottom Feed, Lockstitch Sewing Machine



■ Main Features

1. Alternating presser feet.
2. Steel insert for take-up hinge.
3. By hand or foot operated reverse stitching, stitch regulator & presser foot lifting.
4. Synchronized upper and lower feeding mechanism assures uniform stitching.
5. Extra large, long-beak oscillating shuttle, hook and bobbin.
6. Suitable for stitching extra heavy weight materials.
7. Suitable for sewing such operations and products as safety and logging belts, cargo slings, tents, sails, harnesses, tarpaulins and covers, buffing wheels, fabric structures, parachutes, balloons, industrial bags, construction barriers, boot stitching & book binding etc.

■ Specifications

Sewing speed (spm)	Stitch length (mm)	Needle bar stroke (mm)	Presser foot lift (mm)	Needle	Working space (mm)
700	0-15	66	29 by hand 32 by knee	SM x 1000	413 x 218

TOYOTO

INDUSTRIAL SEWING MACHINE

Changes for the Better...

LZ2-103C Computerized Zig-Zag Sewing Machine for Rope Sewing (special purpose)

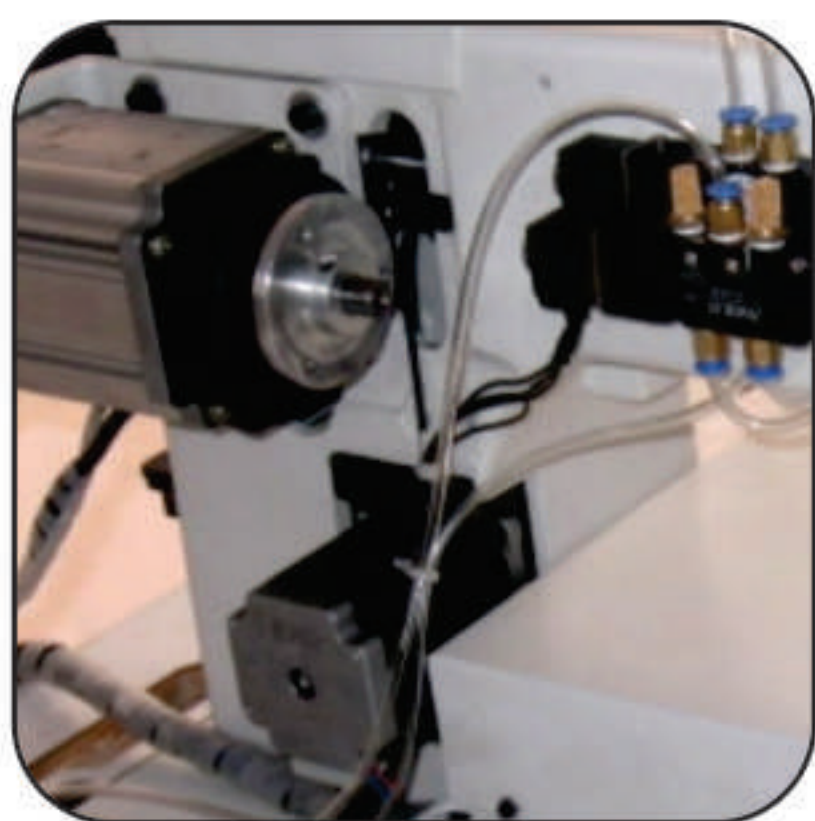
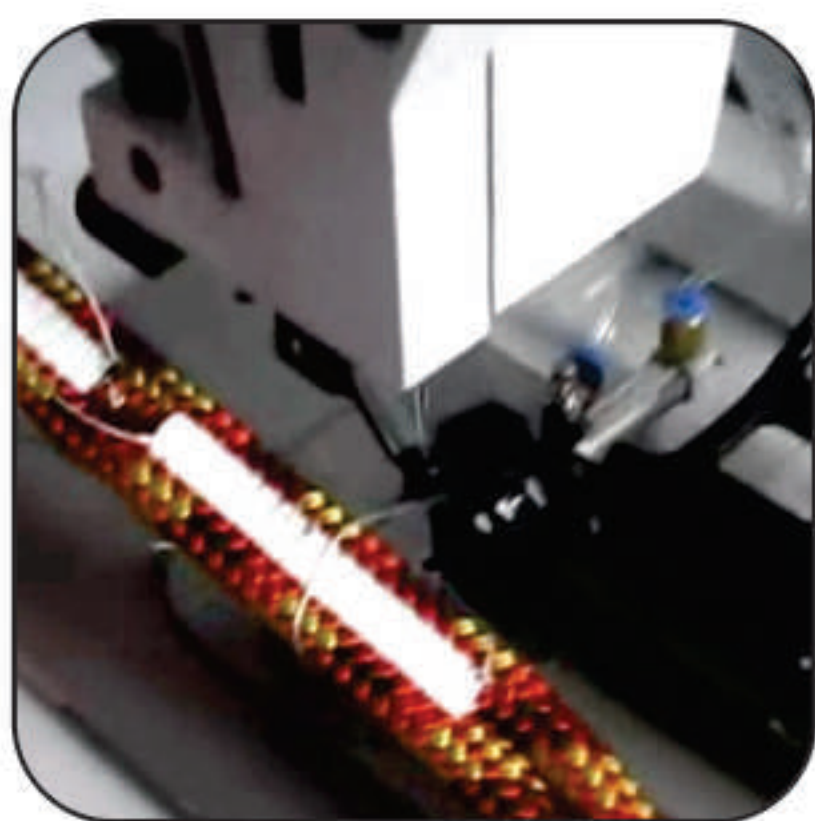

Main Features

1. The machine is programmable for sewing of all types of safety rope.
2. Pattern stitch can be adjustable by the panel.
3. USB cable connected between user computer and the control box.
4. The machine can design the pattern through the computer and store.
5. Two stepping motors drive for X and Y axis.
6. Pneumatic sewing clamp lift & reverse.
7. High torque mini servo motor drive and control.
8. Built-in bobbin winder.



Specifications

Sewing speed (spm)	Clamp size (mm)	Working area (mm)	Needle	Clamp clearance (mm)	Motor
300	150 x 17	130 x 15	7x3, 794	20	Two stepping

TOYOTO

Changes for the Better...

INDUSTRIAL SEWING MACHINE

LZ2-204-105A
LZ2-204-105B

1&2 Needle, Flat bed, Top and Bottom feed,
Large shuttle hook Electronic ornamental Stitch Machine

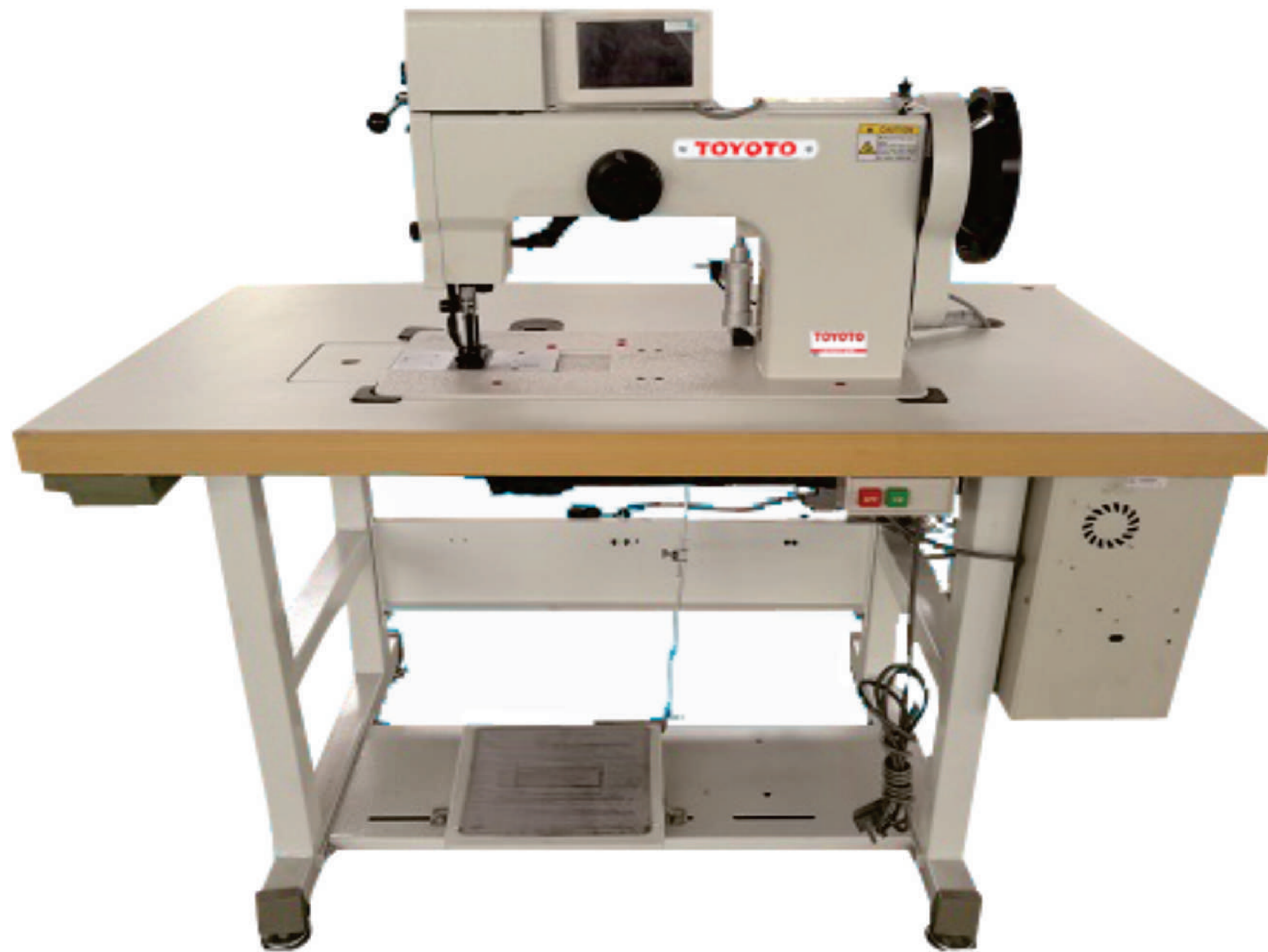

■ Main Features

1&2 needle, flat bed, Top and bottom feed, large shuttle hook, electronic ornamental stitch machine. With 200 different pattern, equipped with a touchable panel, easy to design the patterns on the touchable panel or use a simple software, roller presser foot as optional. For sewing heavy to extra heavy duty materials, such as leather, vinyl, synthetics, etc, suitable for sewing sofa, car seats.

■ Specification

Applications	Sewing speed (spm)	Max. Stitch length (mm)	Presser foot clearance (mm)	Needle gauge	Needle size
Medium~Heavy	600	12mm	12/15mm	6,8,10,12mm	DYx3

TOYOTO

INDUSTRIAL SEWING MACHINE

Changes for the Better...

LZ2-1530AL

HIGH SPEED SINGLE NEEDLE FLAT-BED LOCKSTITCH ZIG ZAG MACHINE WITH DROP FEED (LARGE HOOK, AUTO LUBRICATION)



■ Main Features

1. New mechanism of pendulous needle with fast sewing speed, 2800SPM motor 50mm pulley, 1.5 times higher efficiency.
2. Fully automatic lubrication assures less friction on machine parts; which increases the life of the machine, and lowers the fee for repairing.
3. The lower shaft transfers the movement to the axle of the rotary shuttle.
4. Double the size of a large bobbin reduces the frequency of changing the bobbin thread; and which also rises up sewing efficiency.

■ Specifications



LZ2-1530AL



2800



DP×5 18-19



- - ★



9



6



6/12



23/25



550X250X370

Stitch diagram



TOYOTO

INDUSTRIAL SEWING MACHINE

Changes for the Better...

LZ2-2150M-V

CYLINDRICAL UPPER & LOWER FEED ZIGZAG
INDUSTRIAL SEWING MACHINE
(LARGE HOOK, SMALL CYLINDER, AUTO LUBRICATION)



Main Features

用途：

适用于缝制厚料，各种管状制品，箱包，鞋类，衣帽，沙发，帐篷，高尔夫手套、潜水服等运动用品。

APPLICATIONS：

Suitable for sewing thick materials, various tubular products, especially sports and leather products, such as bags, shoes, hat, sofa, tents, golf gloves, diving suits.

特点：

- 1、圆管直径：70mm 圆管长度：250mm
- 2、采用双压脚上下同步送料，可确保工件平整，缝目均匀美观。
- 3、采用大旋梭，缩短底线换线周期，大大提高缝制效率。
- 4、超低噪音，超低振动，操作简便。
- 5、可选的3点或4点人字车可以增强缝制部分的缝力。

FEATURES：

- 1、Cylinder Dia:70mm;Cylinder Length:250mm
- 2、Adopt double presser foot with upper & lower feed that make the stitching neat and beautiful.
- 3、By adoption of large hook, shorten the bottom line replacement cycles, greatly improving the sewing efficiency.
- 4、Low noise and vibration, easy to operate.
- 5、Optional 2-step or 3-step zigzag sewing machine can enhance the sewing firmness.

型号 Model	最高缝速 Max. Sewing Speed	针摆幅度 Zigzag Stitch Width	针迹长度 Stitch Length	压脚高度 Presser Height By Hand/By Pedal	机针 Needle	缝纫图示 Stitch Pattern
LZ2-2150M-V	1700s.p.m.	10mm	4.5mm	9mm/13mm	DP×17#14-#22	

TOYOTO

Changes for the Better...

INDUSTRIAL SEWING MACHINE

LZ2-2153M-V-BOB-3F
(3 Function in one machine)

Single Needle, Cylinder bed, Large Horizontal axis hook,
Auto Lubrication, Zigzag Sewing Machine

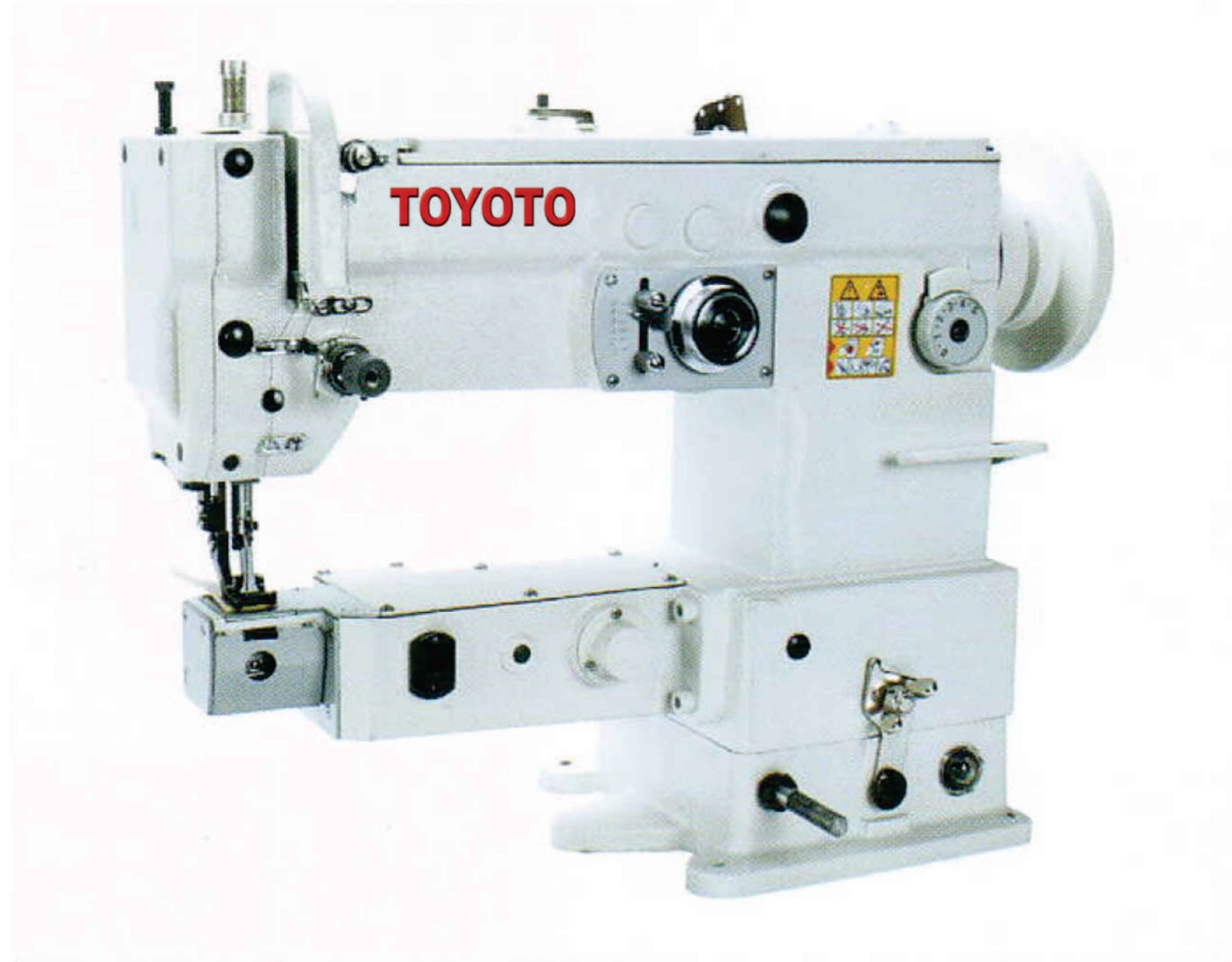
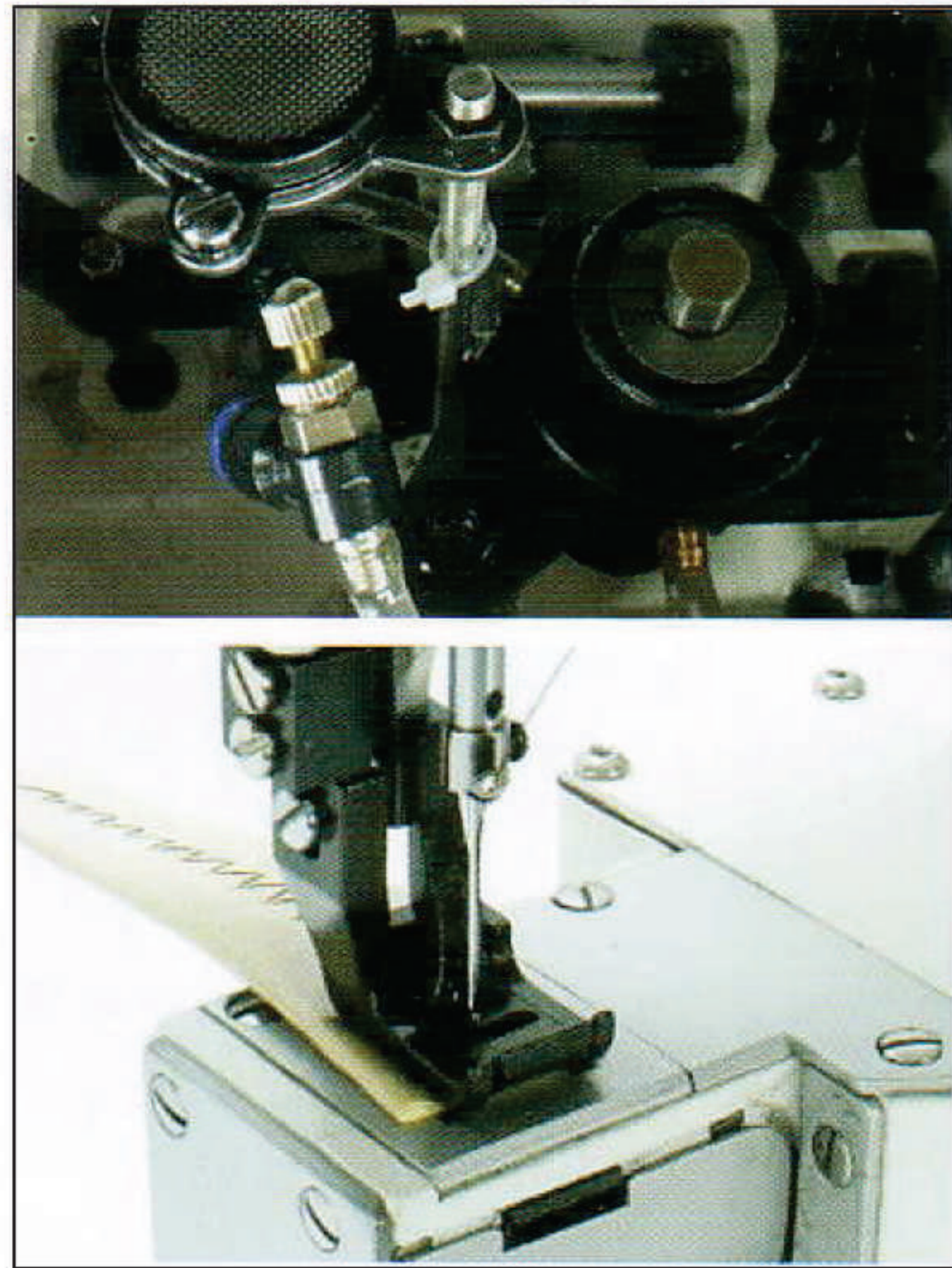

■ Main Features

With change of cam, the machine can be converted from single step zig-zag to two step zig-zag or three step zig-zag.

■ Specification

LZ2-2153M-V-BOB-3F	●	●	—	●	1700	4.5	9/13	10	Dpx17	●	●	●	●